**Please read this
document carefully
before installation!**

**ADSL Loop Extender and
ADSL Loop Extender Power Supply
WH-AE-8001P/2P & WH-AE-AECB1P**

Installation Manual

Version: 004

Preface

This manual provides information on how to use this product. To make the best use of the product, read this manual thoroughly before use. Please keep this manual handy for ease of reference.

- The contents of this document may be changed in the future, without prior notice.
- This booklet was created with thorough attention to the content. If, however, you have a question, spot an error, or find a description lacking, please contact us according to the information in the bottom of the booklet.
- All brand names and trademarks are the property of their respective owners.

Contents

1. Unpack.....	3
2. Technical Features.....	4
3. Installation Environment.....	5
4. Installation Steps.....	6
5. Troubleshooting.....	11

Abbreviations

CO Center Office

CPE Customer Point Equipment

DSLAM [Digital subscriber line access multiplexer](#)

1. Unpack

Unpack equipment carefully; check for completeness against the purchase order. Notify supplier if items are missing.

Note: Save packing material. All equipment returned must be packed in the original packing material.

Inspect equipment for shipping damage, including bent or loose hardware, and broken connectors.

If equipment is damaged in transit, please contact the supplier.

Product list

- ✓ WH-AE-8001P or WH-AE-8002P, one
- ✓ WH-AE-AECB1P, one
- ✓ $\Phi 6\text{mm} \times 30\text{mm}$ nut, one

2. Technical Features

Table 1 – Technical Specifications of WH-AE-8001P/2P

Input Voltage	Powered by ADSL Loop Extender Power Supply	
Power Consumption	WH-AE-8001P	1.3W
	WH-AE-8002P	2.6W
Operating Environment	Temperature	-35°C ~ +50°C
	Relative Humidity	5% ~ 95% (Non-condensing)
Number of supported users	WH-AE-8001P	1 ADSL subscriber
	WH-AE-8002P	2 ADSL subscribers

Table 2 - Technical Specifications of WH-AE-AECB1P

Operating Environment	Temperature	-35°C ~ +50°C
	Relative Humidity	5% ~ 95% (Non-condensing)
Input Voltage	AC 110V or AC220V or DC -48V	
Output Voltage	DC 116V	
Output Current	Less than 50mA	
Fuse Rating	0.5A	

3.Installation Environment

1) the actual lines connecting of equipment

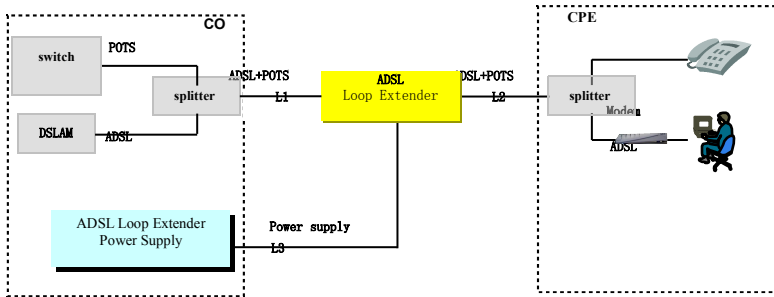

Figure 1 actual lines connecting

L1: The signal twist pair connecting ADSL Loop Extender to DSLAM.

L2: The signal twist pair connecting ADSL Loop Extender to Modem.

L3: The power twist pair connecting ADSL Loop Extender to power supply.

2) Ensure the upstream/downstream rate is no less than 128kbps/512kbps.

3) Resistance and distance demand

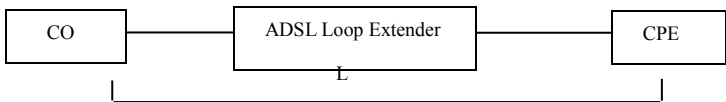

Figure 2 lines connecting sketch map

The recommended installation conditions are as follows.

① 26 AWG twist pair

The demand about resistance and distance is as follows:

Route	Loop resistance demand Ohms	distance demand (Min. Max.)
-------	-----------------------------	-----------------------------

	(Min.-Max.)	kfeet	km
L1(CO-Extender)	450-1260	5.0-13.0	1.5-4.0
L2(Extender-CPE)	200-900	2.0-9.5	0.5-3.0
L(CO-Extender-CPE)	800-1600	6.5-22.5	2.0-7.0

② 24 AWG twist pair

The demand about resistance and distance is as follows:

Route	Loop resistance demand Ohms (Min.-Max.)	distance demand (Min.-Max.)	
		kfeet	km
L1(CO-Extender)	270-1050	5.0-20.0	1.5-6.0
L2(Extender-CPE)	170-1050	3.0-20.0	0.9-6.0
L(CO-Extender-CPE)	550-1550	10.0-29.0	3.0-8.5

If the loop resistance between Extender and Modem is lower than the demand value, the WH-AE-LA800 which you could choose and buy from our company can be added to increase loop resistance. The option WH-AE-LA800 is to be installed between splitter and Modem when used on a line with analog voice. Here is the application of WH-AE-LA800 below:

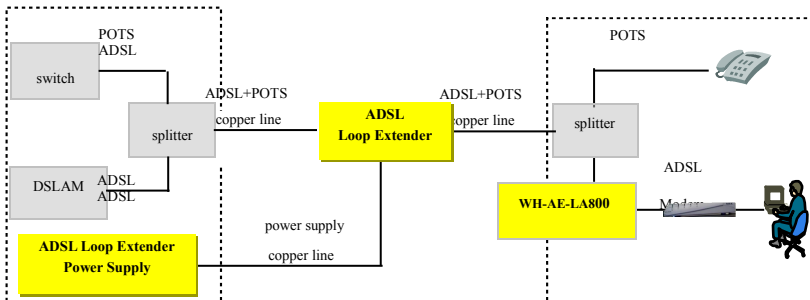

Figure 3 the application of WH-AE-LA800

4. Installation Steps

The WH-AE-8001P or WH-AE-8002P is deployed with WH-AE-AECB1P.

Commonly, the ADSL Loop Extender is installed in the junction cabinet, or on the pole at the middle locality. The Power Supply is installed either at CO or at CPE with remote supply. The details about ADSL Loop Extender and Power Supply installation are as follows:

4.1 Install the Power Supply for ADSL Loop Extender(WH-AE-AECB1P)

1) The actual lines connecting of equipment

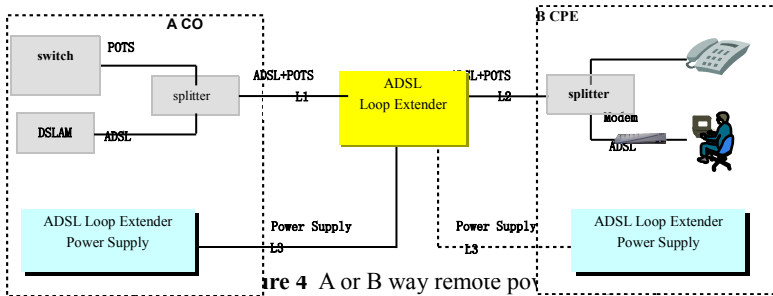

Figure 4 A or B way remote power supply

Generally, the Power Supply can be installed either at CO or at CPE with remote supply, just as the follow Fig5. In the way of A or B, AC110V, AC220V or DC48V can be selected, and two Spare copper pairs are needed for deliver the output voltage to ADSL Loop Extender.

Connect tails

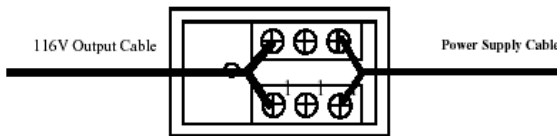

Figure5 WH-AE-AECB1P Connector Wiring Diagram

Three-core power cord without plug: used for DC48V power input, no polarity.

Three-core power cord with plug: used for AC110-240V power input.

Power output: 155V power output cable which is already connected to the terminal in wiring box by factory.

Protection ground: Black protection ground wire should be connected to the protection ground terminals.

Connect the power supply tail (L3)

There is an additional copper pair which powering the ADSL Loop Extender. Now, the supply voltage from wiring box will go through an additional copper pair and into the ADSL Loop Extender directly.

The detail way is as follows:

The Power Supply is installed in the cabinet, and the power supply cable connect with an separate copper twist pair, at the placement of ADSL Loop Extender, the ADSL Loop Extender' blue/white lines connect with the same copper wire pair. For one thing, the cable pair must be free of DC type faults. All shorts, grounds, cross, battery-crosses, and open cable pairs must be identified and repaired.

② Ground

Connect the Power Supply equipment's ground to CO's grounding terminal directly.

③ Connect power cord

The supplied accessories include power cord for AC 110V、 AC220V or DC 48V. Connect it to the AC 110V、 AC220V or DC 48V power source with good connection. To easy the installation, DC power source connection is no polarized. After power supply is connected, the power indicator should be solid on. Flashing indicator indicates short circuits or over-current alarm condition.

Attention: ADSL Loop Extender's Power Supply should NOT be turned on until the ADSL Loop Extender installation is finished.

4.2 Place the ADSL Loop Extender

① ADSL Loop Extender can be placed in the junction cabinet if there is inner room available. Or ADSL Loop Extender can be mounted in the box through supplied mounting brackets.

Attention: Copper-core wire with no less than 1.5mm² section area is required as ground wire. One end of the wire should connect to Loop Extender's ground terminal. The other end of the wire should connect to a good grounding point.

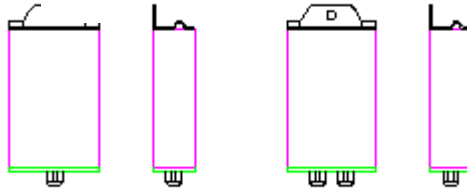

Figure 6 WH-AE-8001P/2P installing Outdoors

Just as the structure above, the ADSL Loop Extender is fixed in the wire rope or in the wall with a fixity.

② Connect the cables

Wiring sockets on front panel for DSLAM and Modem side signal wiring and power supply wiring. Metal bolt on front panel is for ground connection.

Table 4 - Twist-wires Connection Description of WH-AE-8001P

Color	Connection
Blue/White	Remote PWR
Orange/White	to DSLAM
Green/White	to Modem
Brown/White	unused

CAUTION: MUST BE GROUNDED RELIABLY.**Table 5 - Twist-wires Connection Description of WH-AE-8002P**

Cable II		Cable I	
Color	Connection	Color	Connection
Blue/White	unused	Blue/White	Remote PWR
Orange/White	to DSLAM.	Orange/White	to DSLAM.
Green/White	to Modem.	Green/White	to Modem.
Brown/White	unused	Brown/White	unused

CAUTION: MUST BE GROUNDED RELIABLY.

After power on, the “STATUS” LED should be lightened in a few seconds and remain on during normal system operation.

③ Power up

After confirming that all the twist-pair cables are connected correctly and enclosure is securely installed, power up the system. The ADSL Loop Extender will work in 20 seconds after power is supplied steady.

Attention:

- a) “A” and “B” represent A and B wire of the twist-pair. No polarity.
- b) Before power up the system, please make sure all the connections are correct.
- c) When the power supply wire is active, do NOT operate the A and B wire of the supply pair simultaneously. The A wire and B wire should be isolated.

5. Troubleshooting

If the ADSL Loop Extender can't work well, please compare to the Table5 and Table6 to find out the problems.

Table 6 WH-AE-AECB1P Troubleshooting

Problem Description	Possible Reason	Suggested Resolution
Equipment does not work after power-up. Status LED is OFF.	Power supply cable is not correctly connected.	Check power supply cable connection.
Power indicator flashes.	Power output circuitry fails.	Check whether the connection is shorted. Or check whether the connection between Extender and Modem is OK.
Output is OK but the Extender does not work.	Power output cable connection is error or short.	Correct the power output connection or check cable. Or check whether the distance between DSLAM, Extender, Modem is proper.

Table 7 ADSL Loop Extender Troubleshooting

Problem Description	Possible Reason	Suggested Resolution
----------------------------	------------------------	-----------------------------

Extender does not work after power-up. Status LED is OFF.		Power supply cable is not connected properly.	Check power supply and power cable.
No connection	Status LED is always on.	Cables at DSLAM side or Modem side are not connected properly.	Correct the cable connection.
		Line quality is worse between CO and CPE side.	Change good quality cable.
		There is telephone before the splitter on CPE side.	Discard the telephone before the splitter on CPE side.
	Status LED flashes.	Cables linked ADSL Loop Extender are not connected properly.	Correct the cable connection. Or check whether the distance between DSLAM, Extender, Modem is proper.
There is noise in user's telephone		Cable is connected to ground or the insulation is not good caused by men during the construction process.	Check the cables.
		Cable is too near to some electric equipments with strong magnetic field, such as high power sounder, selenium rectifier and high power motor.	Make cable far from the strong magnetic field.
Internet is slow, frequent off-line problem		Affection of computer hardware failures, system failures and virus.	Check computer or take with PC, testers and so on to deal with.
		The parallel cable at CPE side is too long or the connector is oxidation.	It is better to change the parallel cable to copper twist cable.
		The cable to CPE side is connected with too many connectors.	Avoid exposed connectors, use good quality cable instead scattered connectors.